

Collections 2025

IL FANALE

Light and Matter

Collections 2025

IL FANALE

Light and Matter

Pantarhei

by Pierattelli Architetture

Ispirata al principio eracleo del tutto scorre, Pantarhei prende vita attraverso materiali che evolvono, trasformando le proprie cromie con il passare del tempo.

Progettata per gli spazi esterni, la collezione include paletti da giardino in due altezze e una lampada da tavolo ricaricabile, tutti certificati IP65. Gli elementi in cemento, con LED integrato e disponibili in due forme, si uniscono a una solida struttura in ottone anticato, creando un legame armonioso con l'ambiente e il paesaggio. Una luce che non solo illumina, ma dialoga con la natura e con il tempo che scorre.



Inspired by the Heraclitean principle of everything flows, Pantarhei comes to life through materials that evolve, transforming their hues over time. Designed for outdoor spaces, the collection includes garden bollards in two heights and a rechargeable table lamp, all IP65-certified for weather resistance. The concrete elements, featuring integrated LED and available in two shapes, blend with a sturdy antique brass structure, creating a harmonious connection with the environment and landscape. A light that not only illuminates but engages in a dialogue with nature and the passing of time.



331.10.OC
LED 2,5W 3000K

CE IP65 200lm
Driver not included

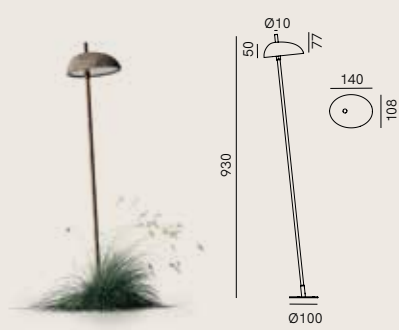

331.11.OC
LED 2,5W 3000K

CE IP65 200lm
Driver not included

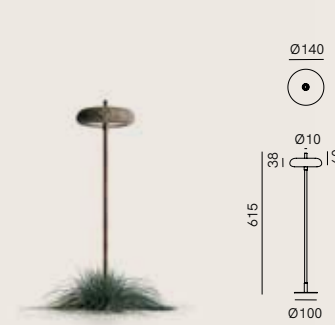

330.10.OC
LED 2,5W 3000K

CE IP65 200lm
Driver not included

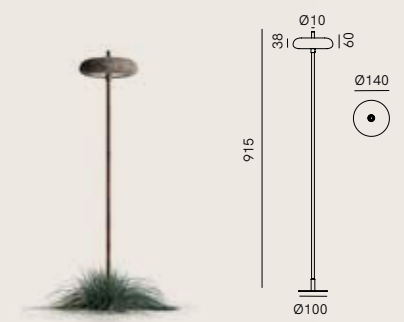

330.11.OC
LED 2,5W 3000K

CE IP65 200lm
Driver not included

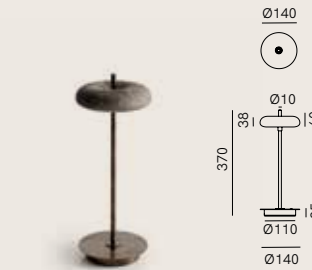

330.15.OC
LED 1,5W 3000K

CE IP65 120lm Touch Dimmable
Output driver 5 Vdc- USB-C

FINITURE | FINISHES

Testa | Shade



Cemento
Concrete

Montatura | Frame



Ottone Anticato
Antique Brass

ACCESSORI | ACCESSORIES

Driver e picchetto disponibili separatamente.
Driver and stake available separately.

Dune

by Sara Moroni

Una reinterpretazione delle forme morbide e increspate delle dune sabbiose modellate dal vento.

Realizzata in ceramica lavorata a mano con terre naturali ricche di ossidi colorati, Dune trasforma ogni pezzo in una micro-scultura luminosa unica. La collezione comprende due sospensioni e due faretti a soffitto (Ø8 cm e Ø10 cm), dove la corona in ottone anticato si arricchisce nell'incontro con la ceramica artigianale, dando vita a un raffinato equilibrio materico. Un dialogo armonioso tra luce, materia e paesaggio.



A reinterpretation of the soft, rippled forms of sand dunes shaped by the wind. Crafted from hand-worked ceramic using natural clays rich in colored oxides, Dune transforms each piece into a unique luminous micro-sculpture. The collection includes two pendants and two ceiling spotlights (Ø8 cm and Ø10 cm), where the antique brass crown is enriched by its encounter with artisanal ceramic, creating a refined material balance. A harmonious dialogue between light, matter, and landscape.

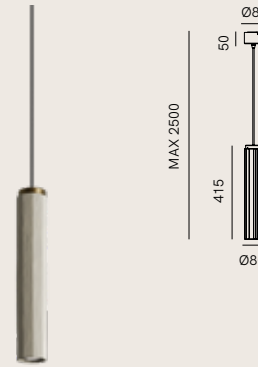

299.01.OC
1 x Max 5W LED GU10

CE IP20 TRIAC/IGBT dimm

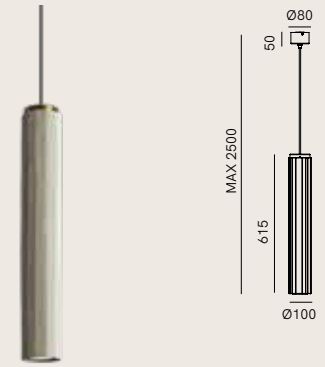

299.02.OC
1 x Max 15W LED E27

CE IP20 TRIAC/IGBT dimm



299.05.OC
1 x Max 15W LED E27

CE IP20 TRIAC/IGBT dimm

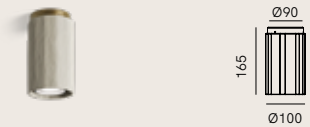

299.06.OC
1 x Max 15W LED E27

CE IP20 TRIAC/IGBT dimm

FINITURE | FINISHES

Testa | Shade



Ceramica grigio chiaro
Light grey ceramic

Montatura | Frame



Ottone Anticato
Antique Brass

Mask

by DT Studio

Un'esplorazione del dualismo tra luce e ombra, capace di svelare nuove atmosfere attraverso il design. Due applique, due identità: una squadrata, essenziale e decisa; l'altra arrotondata, morbida e avvolgente. Rivestite dall'eleganza senza tempo dell'ottone anticato scuro, trasformano le pareti in superfici luminose, giocando con riflessi e contrasti. Grazie alla certificazione IP65, si integrano con versatilità in ambienti interni ed esterni, creando scenari suggestivi e immersivi.



An exploration of the duality between light and shadow, revealing new atmospheres through design. Two wall lamps, two identities: one square, essential, and bold; the other rounded, soft, and enveloping. Clad in the timeless elegance of dark antique brass, they transform walls into luminous surfaces, playing with reflections and contrasts. Thanks to IP65 certification, they seamlessly adapt to both indoor and outdoor spaces, creating evocative and immersive settings.

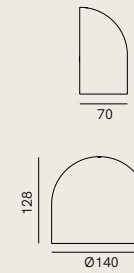

298.01.OS
LED 6W 3000K

CE IP65 LED 750lm TRIAC/IGBT dimm
Driver included

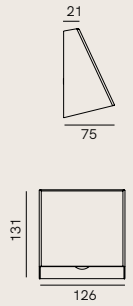

298.02.OS
LED 6W 3000K

CE IP65 LED 750lm TRIAC/IGBT dimm
Driver included

FINITURE | FINISHES

Montatura | Frame

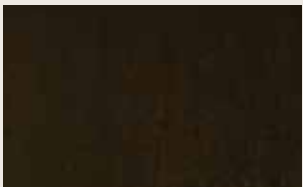

Ottone Scuro
Dark Brass

La Spazio

by Riccardo Attimonelli

Ispirata alla luce che da sempre orienta l'uomo nel buio, La Spazio, firmata Riccardo Attimonelli, reinterpreta la lanterna tradizionale in un'opera di design contemporaneo. Un ponte tra passato e futuro, tra la ritualità della transumanza e l'infinità dello spazio cosmico.

Il gancio a S evoca movimento e continuità, mentre l'ottagono, simbolo ancestrale di armonia, scolpisce la struttura. Disponibile in versione a parete, sospesa e su palo, La Spazio ridisegna gli spazi esterni grazie al gioco di luci ipnotico e dinamico.



Inspired by the light that has always guided humans through darkness, La Spazio, designed by Riccardo Attimonelli, reinterprets the traditional lantern as a contemporary design piece—a bridge between past and future, between the ritual of transhumance and the vastness of cosmic space. The S-shaped hook evokes movement and continuity, while the octagon, an ancestral symbol of harmony, defines the structure. Available in wall-mounted, suspended, and pole-mounted versions, La Spazio transforms outdoor spaces with its hypnotic and dynamic play of light.

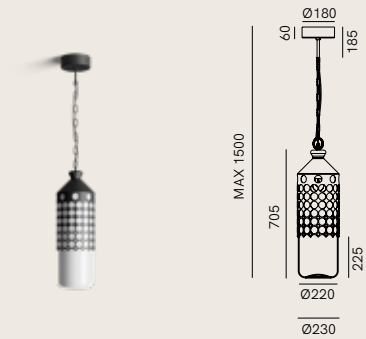

332.01.NN
1 x Max 15W LED E27

CE IP65 TRIAC/IGBT dimm

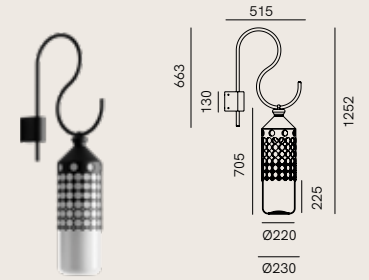

332.04.NN
1 x Max 15W LED E27

CE IP65 TRIAC/IGBT dimm

FINITURE | FINISHES

Montatura | Frame

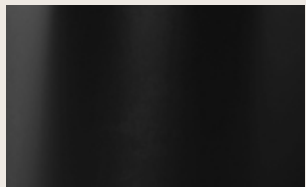

Ferro nero opaco (RAL 9005)
Matt black iron (RAL 9005)

Vetro | Glass

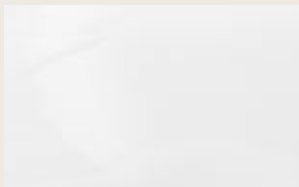

Bianco
White

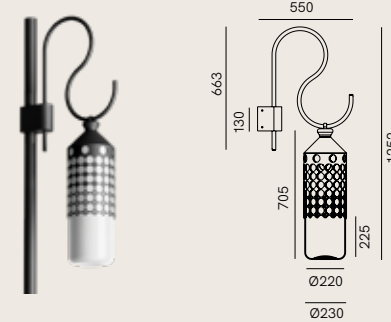

332.07.NN
1 x Max 15W LED E27
(senza palo_without pole)

CE IP65 TRIAC/IGBT dimm

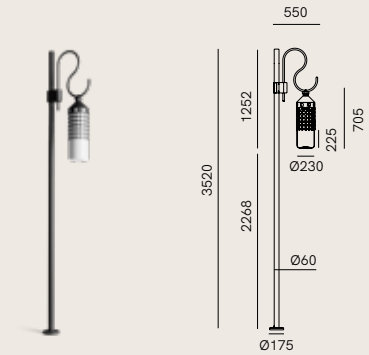

332.20.NN
1 x Max 15W LED E27
(palo incluso_pole included)

CE IP65 TRIAC/IGBT dimm

Designer BIOGRAPHY



Pierattelli Architetture

Ogni progetto di Pierattelli Architetture è un racconto su misura, in cui il passato dialoga con il presente per creare spazi armoniosi e autentici. Fondata a Firenze nel 1980 e oggi guidata da Massimo Pierattelli con i figli Andrea e Claudio, lo studio ha ampliato la sua presenza con una sede a Milano e progetti di rilievo come il Learning Center di Poste Italiane.

Specializzato inizialmente in headquarters bancari e aziendali, ha sviluppato un approccio basato su semplicità formale, materiali locali e sostenibilità, che si riflette anche in ambiti residenziali e dell'ospitalità, con realizzazioni come Yellow Square Firenze e il boutique hotel Pieve Aldina nel Chianti.

Con uno sguardo rivolto all'innovazione, lo studio progetta spazi che fondono tradizione, estetica e funzionalità, consolidando il proprio ruolo nell'architettura contemporanea.

Every Pierattelli Architetture project is a tailor-made narrative, where the past interacts with the present to create harmonious and authentic spaces. Founded in Florence in 1980 and now led by Massimo Pierattelli alongside his sons Andrea and Claudio, the studio has expanded its presence with a new office in Milan and key projects such as the Learning Center for Poste Italiane.

Initially specializing in banking and corporate headquarters, the studio has developed an approach based on formal simplicity, local materials, and sustainability, which is also reflected in the residential and hospitality sectors, with projects like Yellow Square Florence and the boutique hotel Pieve Aldina in Chianti. With an eye on innovation, Pierattelli Architetture designs spaces that blend tradition, aesthetics, and functionality, further establishing its role in contemporary architecture.

pierattelliarchitettura.it



Sara Moroni

Dopo una laurea magistrale in Disegno Industriale del Prodotto al Politecnico di Milano con specializzazione in lighting design, conseguita con il massimo dei voti sotto la guida di Carlotta De Bevilacqua, inizia il suo percorso come project manager e successivamente come libera professionista, sviluppando un approccio multidisciplinare al design.

Nel 2015 fonda il proprio studio, dedicandosi alla progettazione e direzione artistica nei settori del product, furniture, interior, exhibit, lighting e communication. La trasversalità progettuale diventa il suo modus operandi, collaborando con aziende internazionali e realizzando prodotti coperti da brevetti internazionali.

I suoi progetti sono stati pubblicati sulle più importanti riviste di design e architettura e hanno ricevuto prestigiosi riconoscimenti, tra cui il Red Dot Award (2023) in Germania e il Best of Year Award (2024) a New York.

After earning a Master's degree in Industrial Product Design from the Politecnico di Milano, specializing in lighting design, and graduating with top honors under the guidance of Carlotta De Bevilacqua, she began her career as a project manager before becoming an independent professional, developing a multidisciplinary approach to design.

In 2015, she founded her own studio, focusing on design and artistic direction in the fields of product, furniture, interior, exhibit, lighting, and communication. Cross-disciplinary design became her modus operandi, leading to collaborations with international companies and the creation of products covered by international patents.

Her projects have been featured in leading design and architecture magazines and have received prestigious awards, including the Red Dot Award (2023) in Germany and the Best of Year Award (2024) in New York.

saramoroni.com



Riccardo Attimonelli

Nato a Trani nel 1978, si laurea in Architettura al Politecnico di Bari nel 2006. Inizia subito la sua attività nel restauro, progettazione architettonica, design e paesaggistica, operando soprattutto nel settore pubblico. Partecipa alla campagna di scavo a Kos e, nel 2007, consegue un Master in Architettura Bioecologica, ottenendo nel 2013 la qualifica di Certificatore di Sostenibilità Ambientale.

Dal 2009 al 2014 è co-fondatore dello studio associato Labtech, attivo nei lavori pubblici e nelle energie rinnovabili. Nel 2015 fonda Spazio A, trasformato in S.R.L. nel 2023. Oggi è architetto libero professionista e socio di Spazio A S.R.L., occupandosi di interior design, restauro di masserie storiche, progettazione di giardini in aree vincolate e strutture ricettive.

Born in Trani in 1978, he graduated in Architecture from the Polytechnic University of Bari in 2006. He immediately began working in restoration, architectural design, design, and landscaping, primarily in the public sector. He took part in the excavation campaign in Kos and, in 2007, earned a Master's degree in Bioecological Architecture, obtaining the qualification of Environmental Sustainability Certifier in 2013. From 2009 to 2014, he was a co-founder of the associated studio Labtech, active in public works and renewable energy. In 2015, he founded Spazio A, which was transformed into an S.R.L. in 2023. Today, he is a freelance architect and partner at Spazio A S.R.L., specializing in interior design, the restoration of historic farmhouses, garden design in protected areas, and hospitality structures.

spazioassociati.it



DT Studio

DT STUDIO è il cuore creativo di Il Fanale, un laboratorio di design dove tradizione e innovazione si fondono per creare articoli illuminotecnici d'eccellenza, espressione autentica del made in Italy. Attraverso una ricerca attenta su materiali, texture e nuance, dà vita a collezioni dal forte carattere identitario, ispirate a un raffinato metissage Mediterraneo. Guidato da Tomas e Marzia Dalla Torre, DT STUDIO rappresenta il savoir-faire aziendale, reinterpretando la luce in chiave contemporanea con passione e competenza.

DT STUDIO is the creative heart of Il Fanale, a design laboratory where tradition and innovation come together to create outstanding lighting fixtures, a true expression of Made in Italy. Through meticulous research on materials, textures, and hues, it brings to life collections with a strong identity, inspired by a refined Mediterranean fusion. Led by Tomas and Marzia Dalla Torre, DT STUDIO embodies the company's savoir-faire, reinterpreting light in a contemporary way with passion and expertise.

ilfanale.com

Il Fanale Group srl

Via Olivo Bredariol 15
31048 San Biagio di Callalta (TV) Italy
Tel. +39 0422 895200
info@ilfanale.com

